

*Before, During and After*

# Hip Replacement Surgery

*Patient, Family & Caregiver Guide*

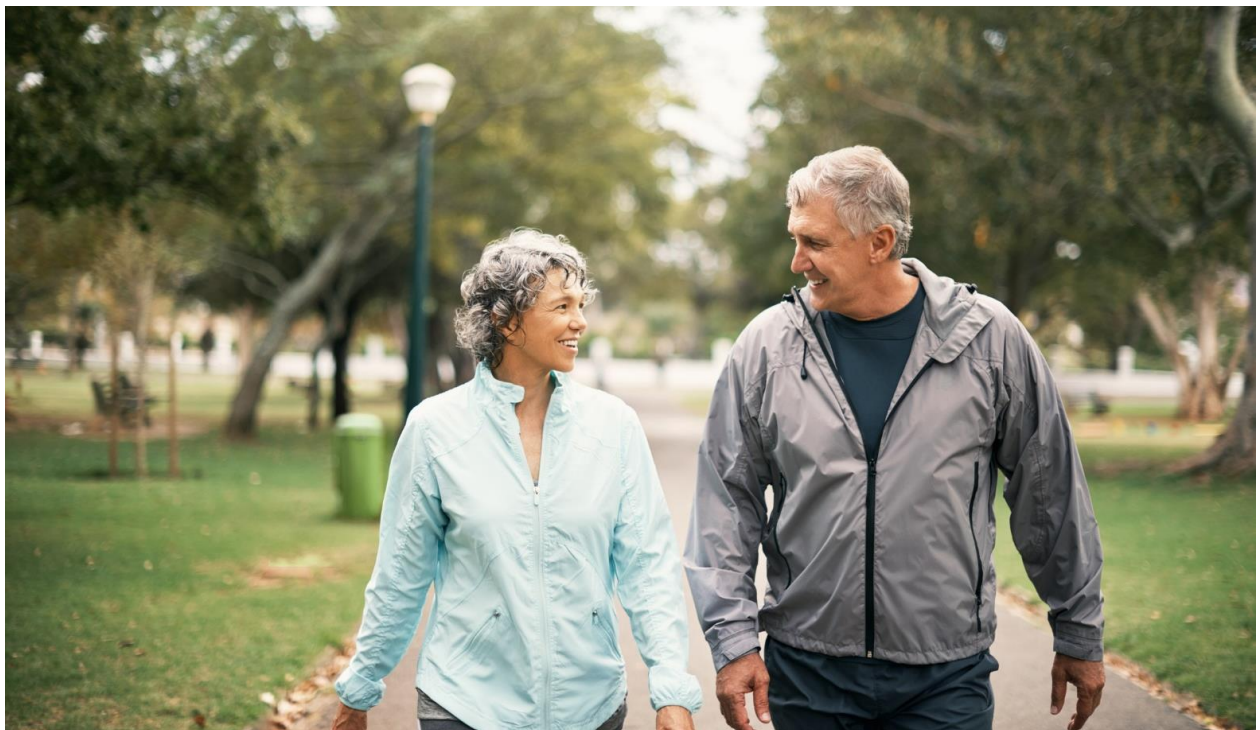

**Dr. Guy  
Dr. St George**



### ***Acknowledgment:***

This booklet was originally produced by Vancouver Coastal Health and the Osteoarthritis Service Integration System (OASIS), and adapted by Brightshores Health System. The Huron Perth Healthcare Alliance would like to generously thank them for permitting us to reproduce this booklet. Some of the information has been slightly adapted by the Huron Perth Healthcare Alliance (HPHA).

# Contents

## Hip Surgery

Hip Anatomy .....	6
Hip Disease .....	6
Total Hip Replacement.....	7
Movement Restrictions .....	8

## Before Surgery

Home Set-Up.....	11
Homemaking - Plan Ahead .....	12
Bathroom.....	12
Seating .....	13
Exercise Before Surgery .....	14
Nutrition .....	15
Stop Smoking.....	16
Bundled Care.....	17
Checklists to Help you Prepare.....	18

## During Your Hospital Stay

Day of Surgery .....	21
During Your Hospital Stay .....	22
Going Home .....	22
Pain Control After Surgery .....	23
Physical Activity .....	24
Follow-Up Appointments .....	24
Bed Exercises .....	25

## After Surgery

Everyday Activity Guidelines ...	27
Bathroom Safety .....	30
Physiotherapy After Hospital.....	31
Pain Control At Home .....	32
Transportation.....	33
Wound Care.....	34
Complications .....	35
Air Travel .....	38
Sexual Activity After Hip Replacement .....	38
Returning to Work .....	38
Long Term Care of Your Hip ...	38
Resources.....	40

## You are about to have hip replacement surgery.

Patients who are prepared for surgery and who take part in their care can recover in less time, with less pain and regain their independence.

This booklet will give you the general information you need to get yourself, your family and your home ready for surgery.

Read this booklet and bring it to the hospital when you go for the operation.

We hope that you find this booklet a useful reference guide before, during and after your joint replacement surgery.

We recommend that you visit the Huron Perth Healthcare Alliance website at [www.hpha.ca](http://www.hpha.ca) and click on “**Hip and Knee Replacement Education**” under Quick Links then choose your Surgeon to view helpful videos and additional information regarding your upcoming surgery.

## IMPORTANT

If your surgeon or health care team gives you different advice than what has been provided in this booklet, please follow the specific directions you receive.

### Do you still have questions about joint replacement surgery?

*Would you like to talk to someone who has gone through the surgery?*

If so, Ortho Connect is for you! It is a program through the Canadian Orthopedic Foundation that will connect you with a volunteer who has gone through a similar surgical treatment. You will be able to ask the volunteer questions about what to expect and get useful tips on how to cope.

*More information is available at: [www.whenithurtstomove.org](http://www.whenithurtstomove.org) (click on “patient resources”)*

*or phone 1-800-461-3639  
or email [mailbox@canorth.org](mailto:mailbox@canorth.org)*

# Hip Surgery

*In this section, you will learn about:*

- Hip anatomy and disease
- Hip replacement surgery
- Movement Restrictions

## Hip Anatomy

- The hip joint is a ball and socket joint, made up of two bones – this allows your hip to move in many directions.
- The ball is the round head of the thigh bone (femur). It moves in the socket of your pelvis (acetabulum).
- There is a smooth elastic type tissue (cartilage) that covers the ball and the socket. This tissue protects the surfaces of these two bones.
- Muscles and ligaments support and strengthen the joint.

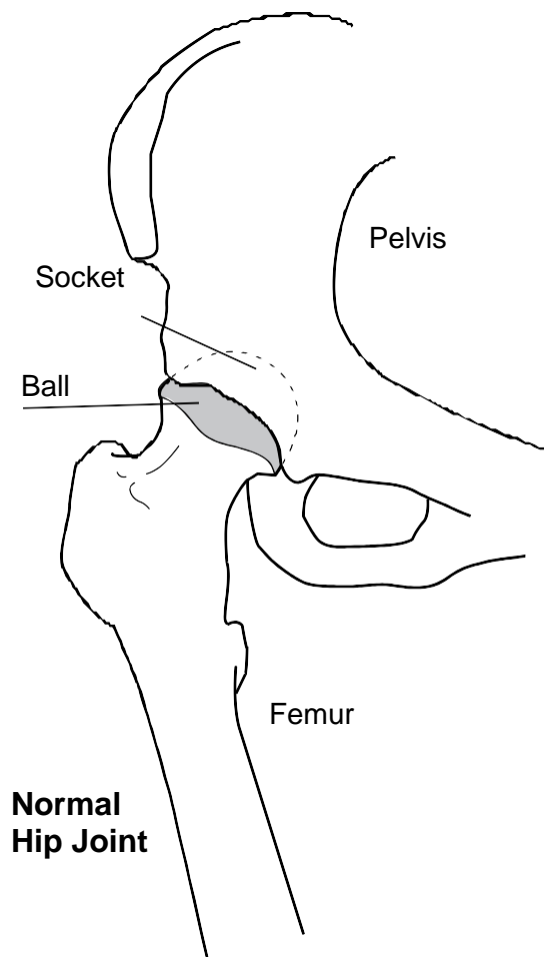

## Hip Disease

- The most common reason for joint replacement surgery is osteoarthritis. Osteoarthritis results in the breakdown of cartilage on the ends of the bones. It usually appears in joints that carry your body weight, such as hips and knees.
- Osteoarthritis, rheumatoid arthritis, bone infection or lack of blood supply to the bone can cause joint pain and stiffness. Pain is most commonly felt in the groin, buttock, thigh and/ or knee.
- Advanced joint damage can be repaired through joint replacement surgery.
- Talk to your doctor if you have questions about your joint health.

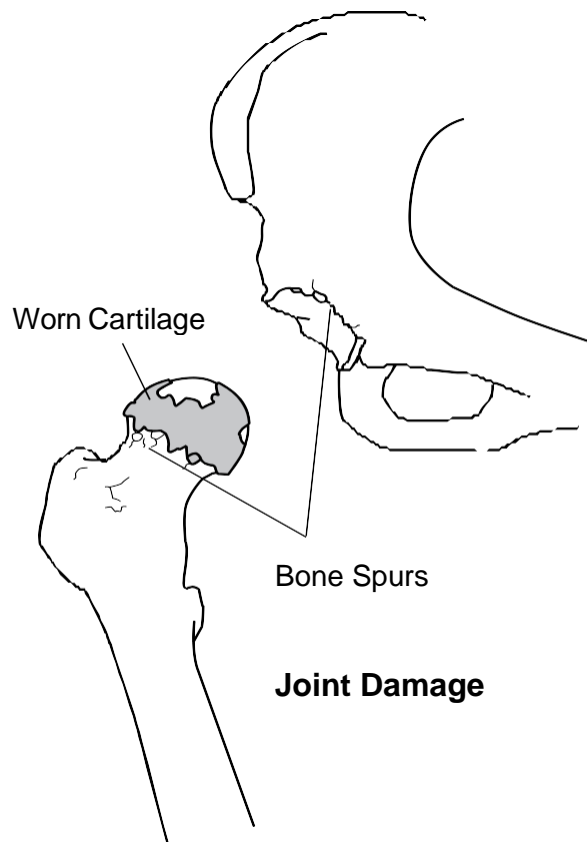

## Total Hip Replacement

In total hip replacement surgery, the surgeon replaces the diseased joint with an artificial joint (prosthesis).

First, the surgeon makes an incision and moves the muscles and ligaments away from the hip joint. Then the head of the thigh bone is replaced with an artificial ball and stem. The stem sits inside the thigh bone. The pelvic socket is smoothed and lined with a plastic or metal cup. Then the joint is put back together with the ball fitted into the cup.

Once the new joint is in place, the muscles and ligaments are repaired. Your skin is closed with staples, which are metal clips that hold your skin together while the incision heals. This surgery takes less than two hours.

Today, many patients who have hip replacement surgery can move their joint better, have less pain and are able to walk more comfortably.

### Artificial Hip Joint

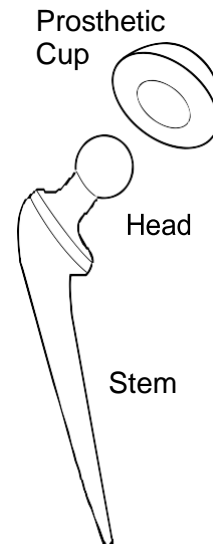
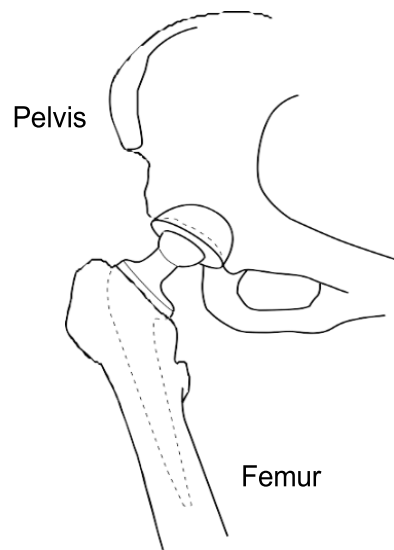

## Movement Restrictions after Hip Surgery

There are *no* specific movement restrictions following your hip replacement surgery.

It is best to avoid extremes of range of motion for the first 4 – 6 weeks.

The following page outlines some suggestions which may make moving easier and more comfortable.



*Shaded leg is the surgical leg.*

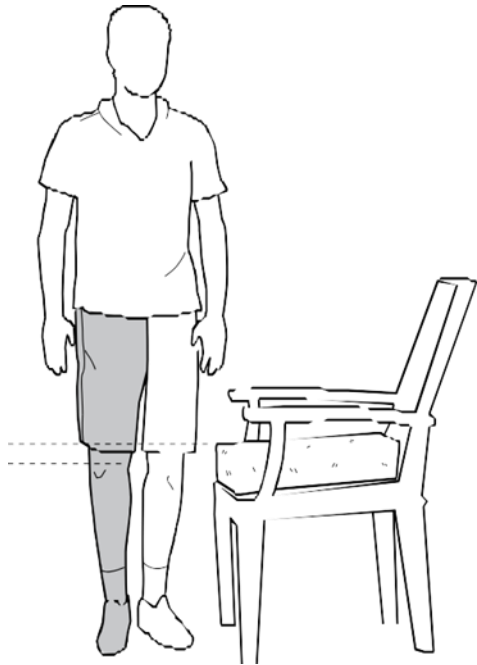

**Sitting on a raised chair or cushion will make it easier to stand.**

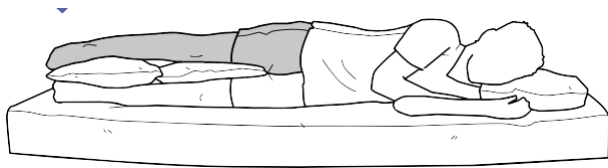

**You may find it more comfortable to sleep with pillows between your legs for the first 6 weeks after surgery to prevent them from crossing.** You can lie on either side but it may be too sore to lie on the operated side. The best option is to lie on your back with a pillow between your legs. You may need assistance placing the pillows or choose to use an extra-long pillow.

**You may find it easier to use long-handled aids, such as a shoehorn and reacher, to help you dress and pick up items.**



Shoehorn



Reacher



A raised seat will make standing from the toilet easier

# Before Surgery

*In this section, you will learn about:*

- Home set-up
- Homemaking
- Bathroom
- Seating
- Exercise
- Nutrition
- Bundled Care
- Checklists

## Home Set-Up

**It is important to set up your home BEFORE joint surgery. This reduces the risk of falls and may make it easier to move around.**

Secure Stair Rails

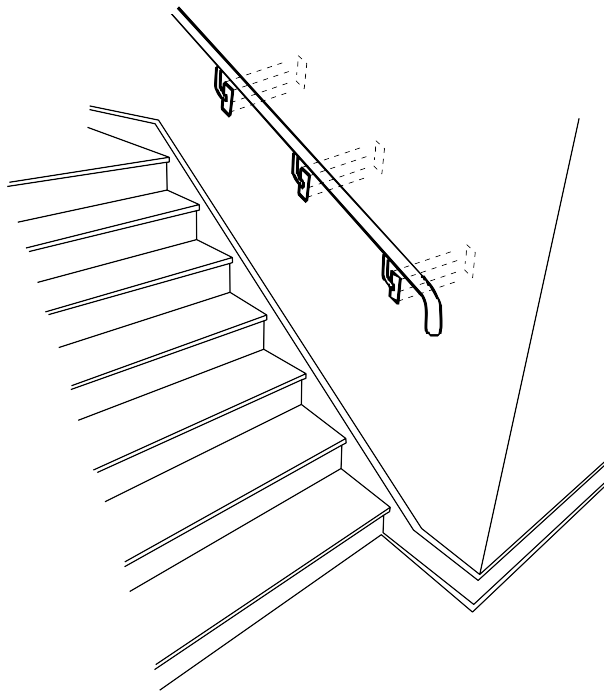

- Ensure hallways and rooms are free of clutter and tripping hazards (e.g. scatter rugs, footstools, telephone and electrical cords, etc.).
- Add non-slip treading to outside stairs and ramps.
- Install stair railings or make sure the existing ones are secure.
- Ensure good lighting in hallways and other well used areas.
- Use night lights, especially between the bedroom and the bathroom.
- Wear non-slip, supportive footwear.
- Wear eye glasses as required.
- DO NOT wax or polish the floors.
- DO NOT try moving too quickly. Let people know that it will take longer to get to the phone or the door.
- Make arrangements before your surgery to have family or friends stay with you if you live alone.
- Some Retirement Homes offer a Respite Stay, which is a temporary accommodation to assist with personal care.

## Homemaking - Plan Ahead

- Arrange for extra help from family or friends for about 12 weeks with household tasks that involve heavy lifting, bending or twisting if needed (e.g. vacuuming, laundry, changing bed linen, garbage).
- Stock your freezer/ pantry with healthy foods and snacks. Private food/ meal delivery services such as Meals on Wheels may be available in many areas.
- Move frequently used household items to counter height (e.g. pots and pans). Consider moving items in the lower parts of the fridge/ freezer to a higher shelf. For items placed high or low, use a reacher.
- Rather than bending down to the oven, use a microwave or toaster oven at counter height.
- Many jobs in the kitchen can be managed safely and easily by sitting on a kitchen chair.

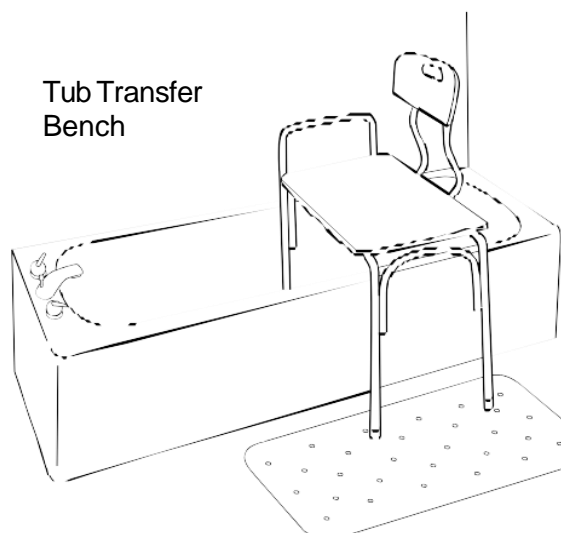

## Bathroom

- Install a raised toilet seat or commode with armrests to help you stand up.
- A commode can be used elsewhere in the home if there is not a toilet nearby (e.g. no bathroom on the main floor or near the bed at nighttime).
- Set up a tub transfer bench in the bathtub or a shower chair in a shower stall. You may need to remove sliding doors from your bathtub and replace with a shower curtain to accommodate the chair.
- Use a non-slip bathmat both inside and outside the bathtub or shower.
- Install a hand-held shower head which makes bathing easier while sitting.
- Use a long handled sponge to help wash feet.
- Grab bars in the bathtub/ shower stall and by the toilet are very useful.
- Do NOT use towel racks, soap dishes, toilet paper holders, or curtain rods to assist you to stand or sit.



## Seating

- A comfortable seat height is 2 inches above your knee.
- Use chairs with firm seats and arms, straight backs and avoid soft chairs/ couches, and rocking chairs.
- Set up a table beside your chair for frequently used items.
- If your bed is low, you may want to add a foam topper, blocks under the bed legs or another mattress.

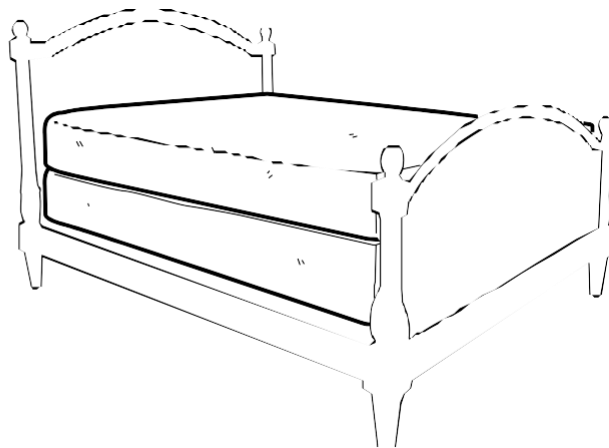
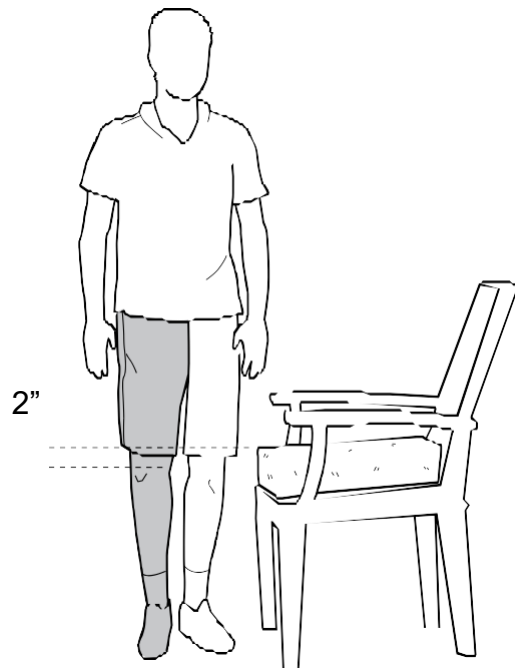

Extra Mattress

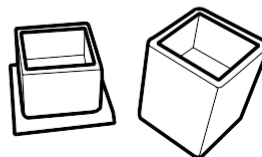
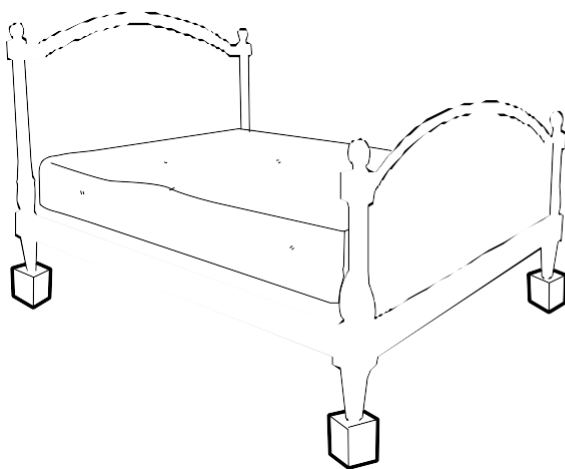

Block

## Exercise Before Surgery

**Exercising before surgery will help you have a faster and easier recovery.**

Do activities that put less stress on your joint.

Try:

- exercises in water, such as swimming or water walking at a community pool,
- cycling,
- Nordic pole walking,
- gentle stretching, strengthening, and specific exercises suggested by a physiotherapist,
- balance exercises (valuable in preventing falls).

These activities will make your muscles strong, improve your endurance and help keep your joint moving. Exercising before surgery will also help you to build up your confidence and knowledge of how to exercise after surgery.

***\*REMEMBER: After surgery, daily exercise will be part of your recovery for many months.***

Be sure to strengthen your arm muscles. You will need strong arms after your surgery to use walking aids, get in and out of bed, and get on and off a chair. If possible, do strengthening exercises before surgery. For example: while seated, push up through your arms. Work up to 10 repetitions, 2 times per day.

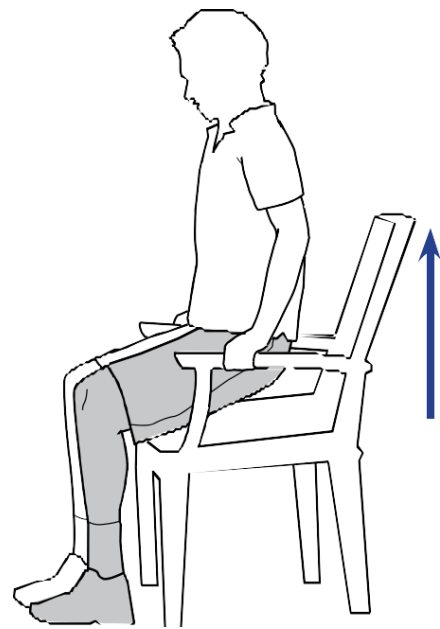

***Always talk to your family doctor before starting a new exercise program.*** If you don't know how to get started, talk to your family doctor or a physiotherapist.

**Exercises for your hip should be practiced before surgery.**

**See page 25 for exercises #1-6. These should be completed at least once daily up until your surgery.**

## Nutrition

Good nutrition helps you to recover from surgery and reduces the risk of infection. Important nutrients before and after surgery include:

### Protein

Your body needs extra protein to heal. Try to include a good source of protein (animal or plant) at all of your meals. Fill  $\frac{1}{4}$  of your plate with protein foods. Choose plant-based protein foods more often. Protein is found in meats, fish, poultry, eggs, milk, cheese, yogurt, tofu, lentils, beans, nuts and seeds.

### Calcium and Vitamin D

Calcium and Vitamin D are important for strong bones. Aim for about 1200 to 1500 mg of calcium each day. Calcium is found in milk, cheese, yogurt, fortified soy beverage, calcium-fortified orange juice, kefir, beans, tofu, nuts and fish. Some vegetables and fruit contain calcium as well. Try to get more calcium through food and take a calcium supplement as a top up to food.

Vitamin D helps your body absorb and use calcium. Vitamin D is found in fish, milk, egg yolks, fortified soy beverage and margarine. Since few foods are sources of Vitamin D, it is recommended adults over the age of 50 years to take a vitamin D supplement of 400 IU each day. Talk to your Doctor, Pharmacist or Registered Dietitian about current supplement recommendations that are right for you.

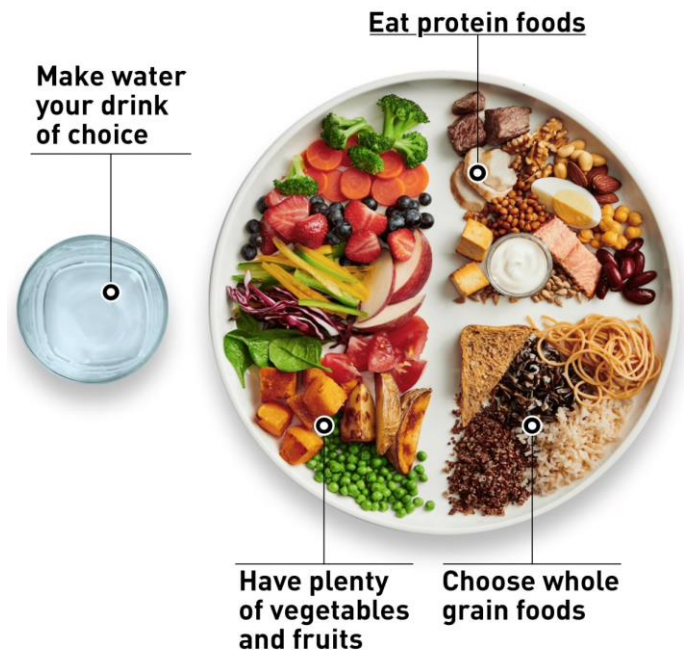

### Fibre and Water

It is important to have a regular bowel habit before joint surgery because constipation can be a complication. It is important to drink plenty of water and eat fibre after surgery to prevent constipation. Include fibre in your diet, such as whole grains, bran, fruits, vegetables, beans and lentils. Spread the fibre throughout the day and drink at least 8 cups of fluid each day.

### Vitamins and Minerals

If you have anemia because of low levels of iron, B6 or B12, talk to your Doctor, Pharmacist or Registered Dietitian at least 2 to 3 months prior to surgery about ways to get more of these in your diet and taking supplements to raise your levels.

*For more information about nutrition, see Canada's Food Guide: [www.healthcanada.gc.ca/foodguide](http://www.healthcanada.gc.ca/foodguide)*



## Stop Smoking for Safer Surgery

Smoking increases your risk of problems during and after your surgery. Quitting 4–6 weeks before your operation and staying smoke-free 4 weeks after it can decrease your rate of wound complications by 50%. Quitting permanently can add years to your life.

You will get the most health benefits if you quit smoking at least 4-6 weeks before surgery, but you will still get some benefits all the way up to one week before surgery!

### Why is it important to stop smoking before surgery?

The longer you are smoke free before your surgery, the more health benefits you will gain, like:

- Faster recovery
- Faster wound healing
- Reduced risk of heart attack
- Shorter stay in hospital
- Less likely to be transferred to critical care unit
- Less likely that your surgical site will get infected
- Less likely to need further surgery



### Need help to stop smoking?

- Odds are you have tried quitting smoking before
- Don't give up
- There is help in your community
- Find the approach that is right for you

### More information about quitting smoking

- Huron Perth Public Health  
[hpph.ca/en/health-matters/smoking\\_tabacco.aspx](http://hpph.ca/en/health-matters/smoking_tabacco.aspx)
- Canadian Cancer Society – Smokers Helpline  
[smokershelpline.ca](http://smokershelpline.ca)
- Ontario Government  
[ontario.ca/page/support-quit-smoking](http://ontario.ca/page/support-quit-smoking)
- Ontario Anesthesiologists – Stop Smoking for Safer Surgery  
[ontariosanesthesiologists.ca/what-we-do](http://ontariosanesthesiologists.ca/what-we-do)
- Indigenous Tobacco Program  
[tobaccowise.com](http://tobaccowise.com)

**My surgery date is:**

---

**My quit date is:**

---

**The sooner you quit, the better!**



## Bundled Care

Bundled care is a service for all patients having single (one-sided) hip and knee replacement.

This service helps to ensure that you have all of the supports in place to recover and gain your independence, and best function as soon as possible after surgery.

- Patients must choose an outpatient physiotherapy clinic in the community **before** their surgery.
- There are a number of outpatient physiotherapy clinics that you can choose from. You can find a list of these clinics on the HPHA website at [www.hpha.ca](http://www.hpha.ca).
- **Important!** Patients must call the outpatient physiotherapy clinic of choice **before** their surgery and book the first appointment within 1-week post-surgery.
- Homecare physiotherapy may be offered to a small number of people who meet the criteria.



## Equipment Checklist

*Complete 1 – 2 weeks before surgery*

A list of Equipment vendors can be found on the last page of this booklet



### Mobility Aids

- Standard Walker: no wheels
- Single Point Cane
- Crutches – if there is no handrail at your steps

*Bathroom and Other Aids are optional; evaluate which you feel would be helpful and acquire those as needed.*

### Bathroom and Other Aids

- Bath Transfer Bench
- Raised Toilet Seat with Armrests
- Long Handled Reacher
- Long Handled Shoehorn
- Thermometer

## Pre-surgical Checklist

*Complete before day of surgery*

- Book outpatient physiotherapy once you know your surgery date, for one week after your surgery.**
- Practice the exercises once a day.
- Check to ensure the seat/ chair heights are set properly.
- Move regularly used items to avoid reaching up or bending over.
- Arrange for help with personal care (foot care, shaving, etc.).
- Arrange for help from family and friends with shopping, laundry, basic housework.
- You should arrange to have someone stay with you for at least the first 48hours post discharge. Pre-Book Respite stay in a Retirement Home, if needed.



- Plan to have a phone that can be carried with you, or plan to have someone with you at all times.
- Remove clutter around the house so that you can move around with your walker easily.
- Plan for help to care for your pets.
- Arrange for rides to your appointments for at least 6 weeks.
- Ask the person driving you home to keep your walker in the vehicle.

## A FINAL Checklist

Complete before day of surgery.

By now you should have picked up your medical equipment and set up your home.

Here is a final checklist of things you need to do before coming to the hospital.

Pack your bag for the hospital including:

- Patient Education Booklet
- Any medications you routinely take at home
- Toiletry items (toothbrush, hair brush, Kleenex, etc.)
- Loose clothes to wear home
- Comfortable footwear with non-slip soles that allow room for possible swelling (such as Crocs, Birkenstocks).
- Eyeglasses, hearing aids (and extra batteries)
- You may want to bring reading materials or leisure activities



***Please do not bring valuables to the hospital.***

## The Evening Before Your Surgery

- Shower using soap and water
- Wash your hair with shampoo
- DO NOT eat anything after midnight
- We encourage you to reduce or quit smoking 2 weeks prior to your surgery
- DO NOT smoke 8 hours before your surgery
- DO NOT apply any makeup, nail polish, deodorant, lotion or perfume
- You can drink clear liquids such as water or apple juice up until 3 hours prior to the time of your surgery
- Nothing to drink 3 hours prior to your surgery

# During Your Hospital Stay

*In this section, you will learn about:*

- Day of surgery
- Days following surgery
- Going Home
- Pain control
- Physical Activity
- Follow-up Appointments
- Bed Exercises

## Day of Surgery

### Before Surgery:

- Take only the medication that you have been instructed to take by the hospital healthcare team with a small sip of water.
- Upon arrival at Hospital, proceed to Surgical Services waiting room in the East Building on the second floor. Volunteers can help guide you.
- To prepare for surgery, you will change into a hospital gown and a nurse may start an intravenous line (IV) in your arm.

### After Surgery: Recovery Room

- You are moved from the operating room to the recovery room.
- You may have oxygen by mask for a short time or nasal oxygen overnight.
- The nurse monitors your vital signs, including your pulse and blood pressure.
- You will have pain medicine on a regular basis. Tell your nurse if you are in pain. You may have a pain button to give yourself medication.
- The stay in the recovery room is usually 1-3 hours.
- If your surgery has been scheduled for Same Day Discharge, you will be seen by Physiotherapy in the Recovery Room prior to discharge home.

### After Surgery: Surgery Unit/Hospital Admission

- Once you are medically stable, you are moved to the surgery unit.
- You may have an intravenous line (IV) for medicine.
- You may have a pillow placed between your knees.
- You may have blood taken.
- The nurse will regularly check your:
  - pain level and comfort level,
  - breathing, blood pressure, pulse and temperature,
  - sedation or level of sleepiness,
  - ability to feel or move your legs,
  - ability to pass urine,
  - drains and dressing,
  - blood sugars.
- You may get up to a chair or walk with the assistance of the nurse or Physiotherapist.
- You will walk to the bathroom with assistance from the nurse.
- You will start with sips of fluid and increase to a regular diet.
- You may be started on an anti-blood clotting medicine after surgery to help reduce your risk of developing a blood clot.
- You may start exercises #1-4 on the Exercise Sheet (page 25).

## During Your Hospital Stay

### With your nurses:

- Nurse will check your dressing, blood pressure, pulse, and temperature regularly.
- Blood tests will be done.
- You will receive pain medications, antibiotics, stool softeners, and blood clot medication as needed.
- You may eat a regular diet and continue drinking plenty of fluids.

### With your Physiotherapist:

- A Physiotherapist will teach you how to properly get in and out of bed.
- Your Physiotherapist will teach you how to properly walk with your walker, and practice walking.
- You will sit up in a chair for your meals , and at other times as you desire.
- Bed exercises are reviewed.
- Discharge plans are reviewed
- You may practice stairs if you are ready to go home.

## Going Home

You will be ready to go home when you have accomplished the following goals:

- Able to get in and out of bed independently (or with minimal assistance if you will have help at home.)
- Able to walk short distances with your walker independently.
- Able to do your bed exercises.
- Able to go up and down steps safely, if you have steps at home.
- Your pain is managed.

Most people are discharged home the morning after surgery.

## Pain Control After Surgery

- Your nurse will teach you how to use the pain scale to describe your level of pain. “0” is no pain and “10” is the worst possible pain.
- Generally, pain medicine is given as a pill. A combination of medicines will likely be used to control your pain after surgery. This normally would include acetaminophen (e.g. Tylenol™) plus possibly an anti-inflammatory (e.g. NSAID) and/ or narcotic (e.g. morphine). By taking a combination of these medicines, you may be able to reduce the side effects and have improved pain control. It is important to talk to your healthcare team to understand how and when to take these medicines.
- Some side effects of pain medicine can include nausea, headache, vomiting, drowsiness, itchiness, inability to urinate and/ or constipation. Tell your nurse if you have any of these symptoms.
- ***It is our goal to keep your pain at “3-4” at rest (may increase with exercise)***

### Wong-Baker FACES® Pain Rating Scale



## Physical Activity

Physical activity is a very important part of your recovery. Not only does it help to improve the function of your joint, but it also helps clear your lungs, reduces the risk of blood clots in your legs, reduces pain, gets your bowels moving and also decreases your risk of pressure ulcers or “bed sores”.

The Therapy staff will work with you throughout your stay to review and practice how to:

- do your daily exercises,
- walk with a walker,
- transfer in and out of bed under home conditions,
- use the stairs safely, if applicable.

The Therapy staff will also:

- encourage you to continue your exercise program at home,
- review the activities you should continue to do at home,
- review that you have an appointment with a physiotherapist in your local community.

## Follow-up Medical Appointments

- Arrange an appointment with your family doctor to remove your staples, 10-14 days after surgery
- Your surgeon, usually around 4 – 6 weeks after surgery
- Your family doctor, once you are back on your feet, to review your general condition
- Your follow-up appointment with an outpatient Physiotherapist should have been arranged before coming to the hospital.



## Bed Exercise Program

- Do not hold your breath while doing the exercises.
- It is your responsibility to ensure that the exercises are done 3 times a day. Feel free to ask for help from therapy staff, family or nursing, if required.
- Ensure bed is flat before starting your exercises.
- 

### #1 Deep breathing and coughing

Take 10 deep breaths followed by 3 coughs every hour to keep your lungs clear.

### #2 Ankle pumps

Pump ankles up and down, 10 times each hour throughout day and night when awake.

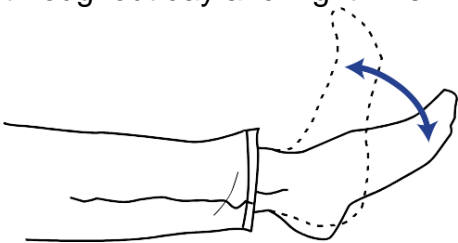

### #3 Quad sets

Push the back of your knee down against the bed and tighten the muscle on the front of your thigh. Hold for 10 seconds and relax.

Repeat 10 times, 3 times per day.

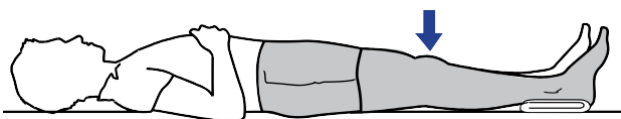

### #4 Gluteal sets

Tighten your buttock muscles together. Hold for 10 seconds and relax.

Repeat 10 times, 3 times per day.

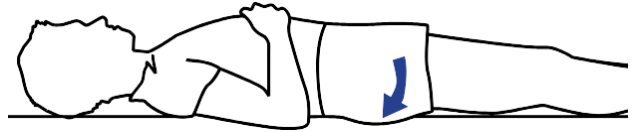

### #5 Knee over the roll

Place roll under operated knee. Keep your knee pressed into roll and lift foot up to straighten leg. Hold for 5 seconds and slowly lower foot back to bed. Use strap to assist if needed.

Repeat 10 times, 3 times per day.

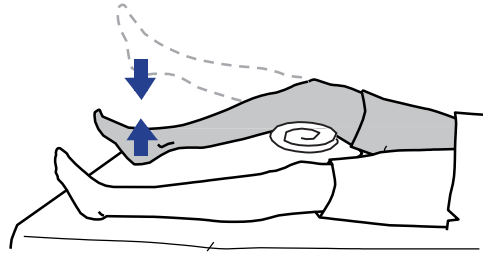

### #6 Hip and Knee Flexion

Bend your hip and knee up through a comfortable range. Slowly slide your foot down until the leg is straight again.

Repeat 10 times, 3 times per day.

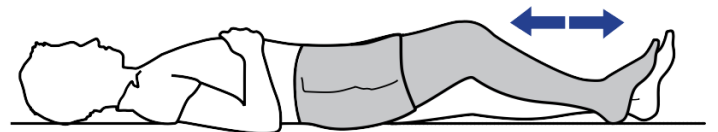

# After Surgery And Beyond

*In this section, you will learn about:*

- Everyday activity guidelines
- Bathroom safety
- Physiotherapy after hospital
- Pain control at home
- Transportation
- Wound care
- Complications
- Air Travel
- Grooming
- Sexual activity
- Returning to work
- Long term care of your hip
- Resources

## Everyday Activity Guidelines

### Getting Out of Bed

- Slide your legs over the edge of the bed while using your arms to push yourself to a sitting position.
- Bring your body to a sitting position at the bedside.

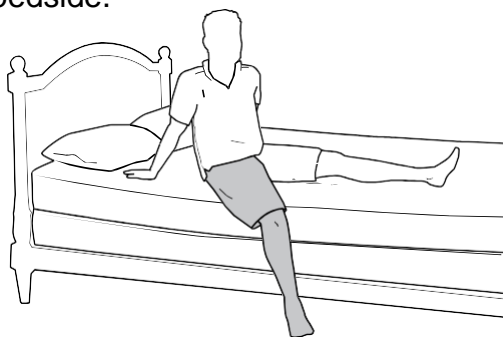

### Getting Into Bed

- Sit at the side of the bed that you normally use at home.
- Slide back across the bed using your arms for support. Position your body, with your back pointing toward the top of the bed.
- Lift legs into bed.
- If needed, you can use a strap to help move your leg.

### Sitting to Standing

- Sit on edge of the bed with your operated leg slightly ahead.
- Place your hands on the bed. Push up through your hand and non-operated leg and then reach for the walker.

*Shaded leg is the surgical leg*



### Sitting Down

- Use a firm chair with armrests.
- Back up to the chair, bed or toilet until you feel the edge behind both your knees.
- Move your operated leg forward and reach back with your hands for the armrests.
- Slowly lower yourself into the chair.

## Walking

You can expect to use walking aids, such as a walker, crutches or cane, for up to 3 months or longer after your operation, based on the guidance of your physiotherapist. By 4-6 weeks after surgery, you should be walking with more confidence, have more strength, and be able to walk longer distances. Regular physiotherapy will help you get the most out of your new joint, have a faster recovery, and will also reduce your risk of developing a blood clot.

### WALKING FORWARD WITH WALKER

- Move the walker forward making sure all four legs are down.
- Move your operated leg forward into the walker.
- Push through your arms on the walker as you step forward with your non-operated leg to be equal with operated leg.
- Repeat this to continue to walk forward.

## Getting Dressed

- Sit on a raised chair or bed.
- Dress your operated leg first and undress it last.
- If needed, you can use adaptive aids like a long-handled reacher, sock aid and shoehorn to reach the foot of your operated leg and put on socks, pants, shoes, etc.
- If there is someone at home who can help you get dressed, you may not need to use these devices.

*Shaded leg is  
the surgical leg*

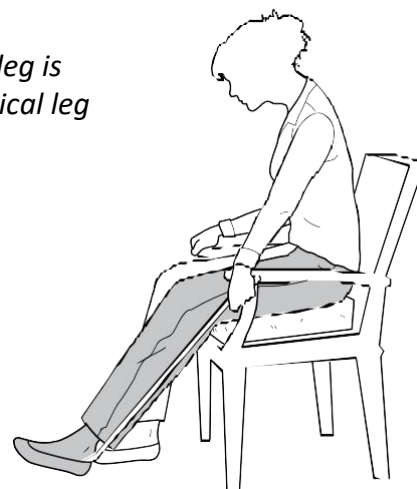

## Stairs

The physiotherapist will determine whether you will use crutches or a cane on the stairs depending on your home. You will practice before leaving the hospital with the therapy staff so that you are able to manage stairs safely and independently.

**REMEMBER: UP WITH THE GOOD, DOWN WITH THE BAD.**

### GOING DOWN STAIRS WITH ONE RAIL AND ONE CRUTCH/ CANE

- Hold onto the rail, place the crutch/ cane in the other hand.
- Place crutch/ cane down onto the step.
- Put weight through the rail, crutch/ cane and the good leg.
- Step DOWN with your bad leg on the step.
- Follow with your good leg down onto the stair, one stair at a time.

*Shaded leg is the surgical leg.*

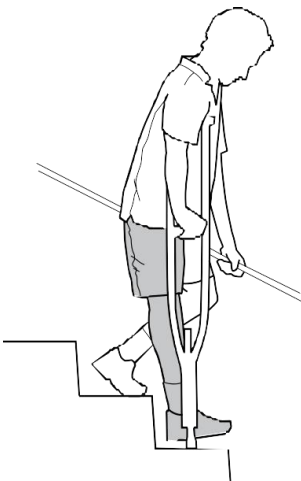

### GOING UP STAIRS WITH ONE RAIL AND ONE CRUTCH/ CANE

- Hold onto the rail, place the crutch/ cane in the other hand.
- Put weight on the rail, crutch/ cane and the bad leg.
- Step UP with your good leg on the step.
- Follow with your bad leg and crutch/ cane, one stair at a time

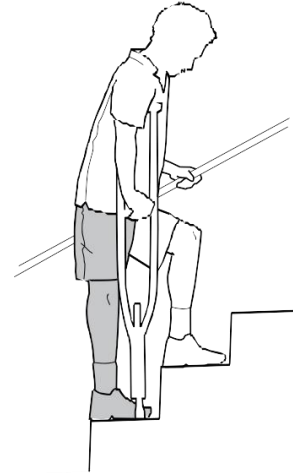

### GOING UP THE STAIRS WITH 2 CRUTCHES:

Installing a railing is the best option, but if this is not an option, you will need to use 2 crutches. It is best to have someone with you when doing stairs with 2 crutches.

- Put weight on the bad leg and crutches, Step UP with your good leg on the step.
- Follow with your bad leg and crutches, one stair at a time.

## GOING DOWN THE STAIRS WITH 2 CRUTCHES:

- Place your crutches on the step below.
- Step DOWN with your bad leg first.
- Put weight through the crutches and bad leg.
- Follow with your good leg, one stair at a time.

## Using the Toilet

- You may want to use a raised toilet seat or commode after your surgery.
- Make sure that the toilet seat has secure armrests. You can also install grab bars to help you stand or sit. Do NOT use towel racks or toilet paper holders to help you stand or sit down.
- Sit down as you would in a chair.



## Bathroom Safety

Falls can happen anywhere but are most likely in the bathroom. Here are ways to reduce the risk:

- Do not rush. Plan to use the toilet often. Have a bedside commode if needed.
- When bathing, use a bench or chair, non-slip bath mats, grab-bars.
- Make sure the path from your bedroom to the bathroom is well-lit.

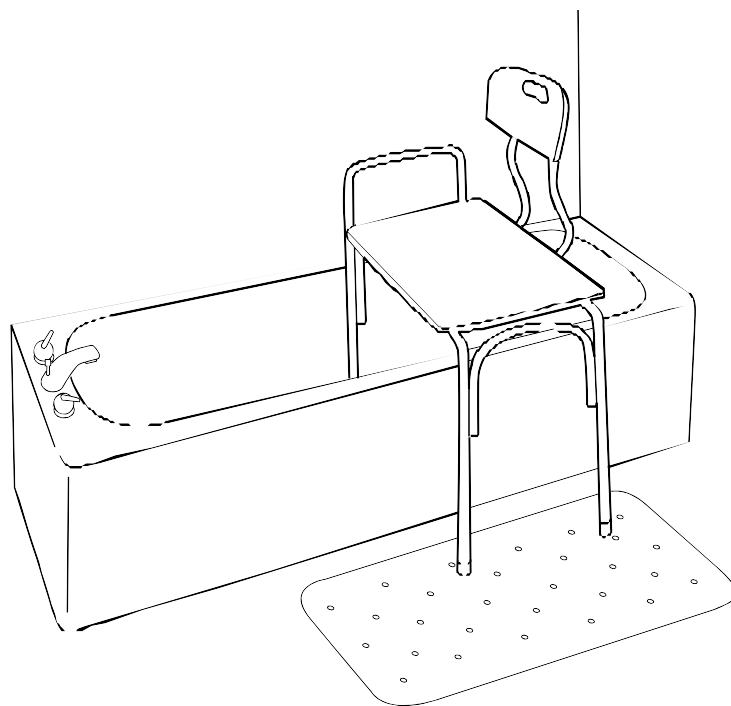

## Bathtub Transfer

- You may choose to use a tub transfer bench with a hand-held shower (in a bathtub) or shower chair (in a shower stall) for the first 6 weeks after surgery. Do NOT sit on the bottom of the tub.
- Sit down as you would in a chair. Slide back as far as you can on the seat. Then lift your legs and slide to clear feet over the edge of the tub.
- Move your body down the bench by pushing up on the bench with your arms and lifting your bottom.
- Use long-handled aids to clean your feet and other hard-to-reach places.

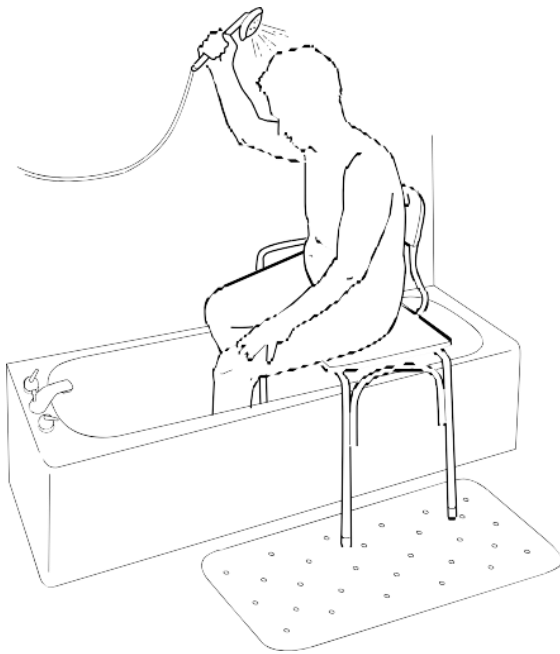

## Physiotherapy After Hospital

Continue the 6 bed exercises you were doing in the hospital, 3 times a day (see page 25).

The hospital physiotherapist will confirm that you have arranged your physiotherapy appointment for when you get home.

Your physiotherapist will give you exercises to stretch and strengthen your legs and improve your walking and balance. As you recover, the exercises will change. Doing the exercises assigned by your physiotherapist will help you move your new joint and enjoy greater independence. It is important to continue with some form of exercise.

Talk to your physiotherapist if you have questions about your exercises or concerns about your progress.

## Pain Control at Home

Most people have less and less pain over the next 6-12 weeks. If pain is preventing you from caring for yourself, sleeping and/or exercising, talk to your physiotherapist or doctor. **If your pain becomes increasingly worse or if you have pain in a new part of your body, seek medical attention immediately.**

### *Here are some ways to manage your pain:*

- Take **pain medicine** as directed. It is normal to have some increased pain or symptoms during physical activity or physiotherapy sessions. It may be helpful to take the pain medicine 1-2 hours before doing these activities in the first weeks after surgery. It is better to take medicine **BEFORE** the pain is severe.
- **Ice** can reduce pain and inflammation. Place an ice pack wrapped in a towel on your hip for no more than 15-20 minutes after exercises.
- **Pace yourself.** Do not push yourself. Regular rest is an important part of your healing process.
- **Relax.** Use relaxation techniques such as breathing exercises or visualization.
- **Distract yourself.** Listen to music, visit friends, write letters, watch TV.
- **Think positively.** You will become more and more comfortable as you recover from your surgery



## Transportation

### Driving

**Driving is not allowed after hip surgery for the first 6 weeks regardless of which hip was operated on.** There are a number of factors that can impact your ability to safely return to driving. These include using mobility aids and taking prescription pain medicines. Talk to your surgeon before driving.



- Move the seat as far back as possible to provide maximum legroom.
- Recline the back of the seat.
- If the seat is low or bucketed, you may want to place a firm pillow or cushion on the seat with the thick end at the back.
- A piece of plastic or a large garbage bag over the cushion may help you to slide in more easily.
- Back up to the seat until you feel the back of the seat on your legs.
- Straighten your operated leg.
- Hold onto the back of the seat and the car to stabilize you.
- Lower yourself to the seat.
- Slide back and gently lift your legs into the car.

### Getting In and Out of Vehicles

- Park away from the sidewalk or curb so you are not stepping down from the curb to the car. If you have a high truck or sport-utility vehicle, you may need to park near the curb so that you do not have to climb up to the seat.

*To get out of the vehicle, use the same steps, in the opposite order.*

*Shaded leg is the surgical leg.*

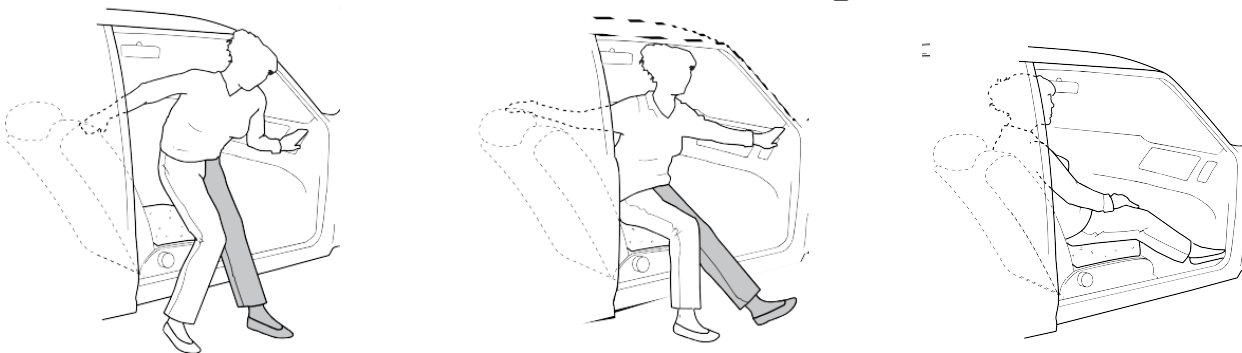

## Wound Care

You will have a cut (incision) at the site of your surgery. Your nurse will teach you how to care for your incision and dressing at home. The edges of your skin are held together with staples, which are metal clips.

- A dressing will be placed on your hip at the time of surgery. This dressing will remain in place for 7 days.
- If your incision is draining and your dressing has become soiled or damp, apply a clean dressing.
- Remember to wash your hands before and after you care for your incision.
- You may shower after the staples are removed if the incision is closed, clean and dry.
- DO NOT soak hip in water. No baths, swimming or whirlpools until after your follow up appointment with your surgeon.
- Staples are to be removed 10- 14 days from the date of your surgery. You must make an appointment with your family doctor to have the staples removed
- Do not apply any creams, ointments or lotions to your incision

## Instructions on How to Change Your Dressing on Day Seven

Gather Supplies – Saline, Gauze, Dressing

1. Wash hands
2. Gently remove old dressing
3. Open 2 packages of gauze
4. Wet gauze by pouring saline onto the gauze pads
5. Take one piece of gauze and gently wipe the center of the incision from the top to the bottom and throw the used gauze in the garbage
6. Use a new moistened gauze and gently wipe to the left of the incision from the top to the bottom and throw the used gauze in the garbage
7. Use a new moistened gauze and gently wipe to the right of the incision from the top to the bottom and throw the used gauze in the garbage
8. Let incision dry completely
9. Remove new dressing from package
10. Pull tabs to remove backing from dressing, taking care not to touch the side that will be against your incision (like a Band-Aid)
11. Apply new dressing over incision – secure dressing by pressing firmly on the outside of the dressing
12. The incision should stay covered until you see your family doctor to have the staples removed

## Complications

If you develop any of the following complications, call your surgeon's office and tell them what you are experiencing. If you are unable to contact your surgeon, go to the emergency department or call 911. Have them contact the orthopedic surgeon on-call prior to starting any antibiotic treatment.

### Call 911 immediately if you have:

- shortness of breath,
- sudden chest pain,
- coughing up blood,
- the surgical leg is suddenly extremely painful, shortened, and/ or the hip cannot be moved.

### Seek medical advice immediately if you have:

- pain, aching, heat or redness in your thigh or calf area of either leg,
- increasing severe swelling in either leg or around incision,
- temperature above 38°C (101°F) taken at least 30 minutes after eating or drinking,
- increased drainage from the incision site, change in drainage (odour), redness, or opening of the incision edges,
- increased difficulty with walking.

## Incision Infection

- The area around your incision is becoming red.
- New green, yellow or foul smelling pus drains from the wound site.
- There is increased pain or swelling of wound site and surrounding area.
- You have a fever above 38°C or 101°F.
- Call your surgeon if you think you have a possible wound infection.

## Urinary Tract Infection

- You have pain when you urinate.
- You have frequent or urgent need to urinate.
- You have foul smelling urine.
- You have a fever above 38°C or 101°F.

## Sore Throat/Chest Infection

- You have swollen neck glands, pain when you swallow.
- You have frequent cough, coughed-up yellow or green mucous, shortness of breath.
- You have a fever above 38°C or 101°F.

## Blood Clots

A small number of people may get blood clots after surgery. Blood clots usually develop in the deep veins in the legs.

You may be at greater risk if you:

- are overweight,
- smoke,
- have cancer,
- have poor mobility,
- have other medical conditions,
- become dehydrated,
- have reduced circulation.

### *To reduce the risk of blood clots:*

- Drink lots of fluids – stay hydrated.
- Take your anti-blood clotting medications as directed.
- Walk short distances at least once an hour (except when you are sleeping).
- When you are sitting or in bed, pump your ankles and tighten your leg muscles.
- Stop smoking and keep a healthy weight.

## Pressure Sores

Pressure ulcers or “bed sores” are skin wounds caused by repeated friction or shearing and staying in one place too long.

*To prevent ulcers:*

- Change your position frequently while in bed or chair.
- Get out of bed or chair often.
- Tell someone if you have pain/ burning in heels, elbows or your bottom.

## Constipation/Bladder Function

Constipation can be a problem after surgery. A change in your diet, less activity and pain medicine may make your constipation worse. Here are some ways to stay regular at the hospital and at home:

- Drink at least 8 glasses of water or low-calorie fluid a day.
- Eat fibre, such as prunes, bran, beans, lentils, fruits and vegetables.
- Move around as much as you can – do your exercises!

Your nurse may give you laxatives and/ or stool softeners. You may need to keep taking these medicines at home. If you have constipation at home, talk to your family doctor or pharmacist. Constipation can be serious so do not ignore your symptoms.

Some patients have difficulty urinating after their joint surgery. Please talk to your nurse right away if you are having problems.

## **Excessive Swelling**

It is normal and natural to have some swelling in your leg after surgery and during your recovery. Swelling may increase as you become more active but should decrease with time and will be less noticeable in the mornings.

*To help reduce swelling:*

- Pump ankles hourly when awake.
- Lie down flat and raise your legs while maintaining hip precautions by placing pillows under the length of your operated leg.
- Change positions frequently. Avoid sitting, standing, and/ or walking longer than 30 minutes at a time.
- Do short periods of activity. Walk a few steps. Rest and repeat.
- Place an ice pack wrapped in a towel on your hip joint for no more than 20 minutes repeated on/ off throughout the day.

## **Joint Infection**

An infection in the body can reach the new joint through the bloodstream. People who develop joint infections often require prolonged antibiotics and subsequent surgery. To prevent infection or incision problems, it is important to keep the incision and dressings dry. Do not touch or pick at the incision and maintain good cleanliness of the surrounding skin.

## **Anemia (low blood count)**

If you have signs of anemia, see your family doctor. You may need an iron supplement. The signs of anemia are:

- feeling dizzy or faint,
- feeling very tired,
- experiencing shortness of breath,
- having rapid pulse.

## **Joint Loosening**

Over many years, the bond between the joint replacement and your bone may loosen. This can cause pain and make it difficult for you to move your artificial joint. To reduce the risk of this complication, avoid high-impact physical activities. If you notice increased pain in your artificial joint, talk to your doctor as soon as possible.

## **Joint Dislocation**

Joint dislocation is rare, but requires immediate medical attention. The signs of dislocation are:

- Extremely painful hip
- Shortened leg
- Difficulty moving

Call 911 or go to the Emergency Room if you are experiencing these symptoms.

## Air Travel

You may have some extra challenges travelling by plane after surgery. Be sure to give yourself extra time when flying.

- Talk to your surgeon about when it is safe to fly after surgery. You will NOT need a special card indicating you have had a hip replacement. The new joint may set off metal detectors at the airport. You may need to show airport security your incision or you may be asked to take the full body scan to prove you've had surgery.
- While on the plane, do foot pumping exercises every hour to help reduce the risk of clots.
- When able, get up and walk around.

## Sexual Activity after Hip Replacement

- You may return to sexual activity when you feel ready and comfortable.
- You may need to consider trying some new positions. Talk to your partner.
- Consider other ways you can express intimacy such as hugging, holding hands and kissing.
- If you have questions or concerns about how to protect your new hip during sexual activity, talk to your surgeon.

## Returning to Work

Allow yourself time to recover from surgery and focus on your rehabilitation before returning to work. Some people return to some form of work quickly after surgery but others need a longer time to heal and recover. This depends on health status and the type of work you do. Talk to your surgeon before planning on returning to work.

## Long Term Care of Your Hip

- Do not lift anything heavier than 50 lbs on a repeated basis.
- Talk to your dentist or surgeon before having any dental work done. You may need to take an antibiotic.
- There is no limit to walking, biking or swimming.
- Some activities, such as running and contact sports, are not recommended after you have had a hip replacement. If you have questions or concerns, please speak to your surgeon.

*We hope you found the information in this booklet useful. We wish you a speedy recovery and many happy, active years with your new joint*

## Questions for your Care Team

### Follow-Up Appointments

#### Physiotherapy

Clinic Name: \_\_\_\_\_

Appointment: \_\_\_\_\_

#### Family Doctor

Appointment: \_\_\_\_\_

#### Surgeon

Appointment: \_\_\_\_\_

## Resources

Current as of May 2020

### Huron Perth Healthcare Alliance

[www.hpha.ca](http://www.hpha.ca)

### Connecting the Dots for Caregivers

[www.caregivershuronperth.ca](http://www.caregivershuronperth.ca)

Connecting you to community resources such as Respite Care and Transportation

### Arthritis & Surgery Information

The Arthritis Society

[www.arthritis.ca](http://www.arthritis.ca)

Arthritis Answers Line: 1-800-321-1433

Ortho Connect

[www.canorth.org](http://www.canorth.org)

### Equipment Vendors

#### Action Health Care

305 Romeo St South  
Unit #3  
Stratford  
519-271-6700

566 Queen Street East  
St. Marys  
519-284-4348  
1-866-222-4843

37 Ontario St N- Unit 3  
Grand Bend  
519-238-8015

### Southwest Healthline

[www.southwesthealthline.ca](http://www.southwesthealthline.ca)

### Health Professionals

Dietitians of Canada

[www.dietitians.ca](http://www.dietitians.ca)

EatRight Ontario

[www.eatrightontario.ca](http://www.eatrightontario.ca)

1-877-510-5102

Ontario Physiotherapy Association (OPA)

[www.opa.on.ca](http://www.opa.on.ca)

TeleHealth Ontario

Free access to a Registered Nurse

Toll Free: 1-866-797-0000

#### Ontario Home Health

221 Huron Street  
Stratford  
519-273-5770  
1-800-661-1912

#### Med-E-Ox

300 Suncoast Drive East  
Goderich  
519-524-2020  
1-800-265-5500

#### Action Medical

3-255 Main Street  
Woodstock  
519-553-0376  
1-877-568-3558





*Before, During and After*  
**Hip Replacement Surgery**  
Patient, Family & Caregiver Guide

---

V2 – June 2024